



## KIT ADMISSION DYNAMIQUE DYNAMIC INTAKE KIT

RENAULT 5 GTD TURBO  
1985

S.A.S

**Chrono'Sport**

122 rue du faubourg Saint Jean  
ZA de l'AVELON - 60000 BEAUVAIS -  
FRANCE

 00.33.3.44.02.64.64

 00.33.3.44.02.87.10

**Part n° :Dw023**

# FITTING INSTRUCTIONS

Remove the pipe A, B and the complete air box. (see diagram A, C)  
Disconnect the flexible breather pipe from the pipe A. (see diagram A)  
Fix the pipe of the kit onto the entry of the turbo. (see diagram B)  
Fix the TWISTER onto the pipe of the kit with the clamp provided  
(see diagram B)  
Fix the air pipe onto the air pipe and the TWISTER in order to have  
fresh air into the TWISTER. (see diagram B)  
Fix the air pipe with the plastic clamps provided.

### CAUTION

To have good performance from your TWISTER, the filter must be filled  
with the ducting kit with the sheath. (See diagram C)  
Adjust the TWISTER so that it does not touch a mechanical part.

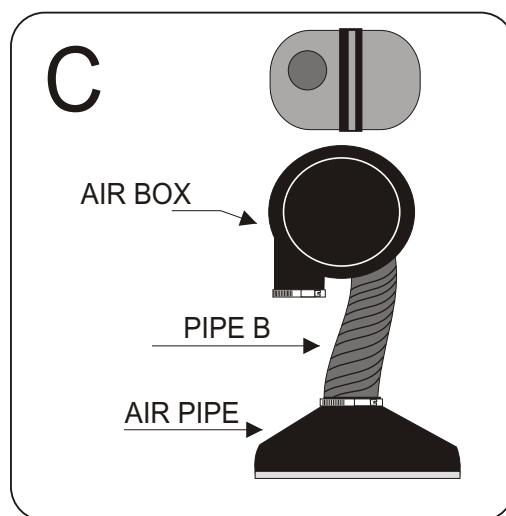

ORIGINAL INDUCTION SYSTEM  
UPPER VIEW OF THE ENGINE

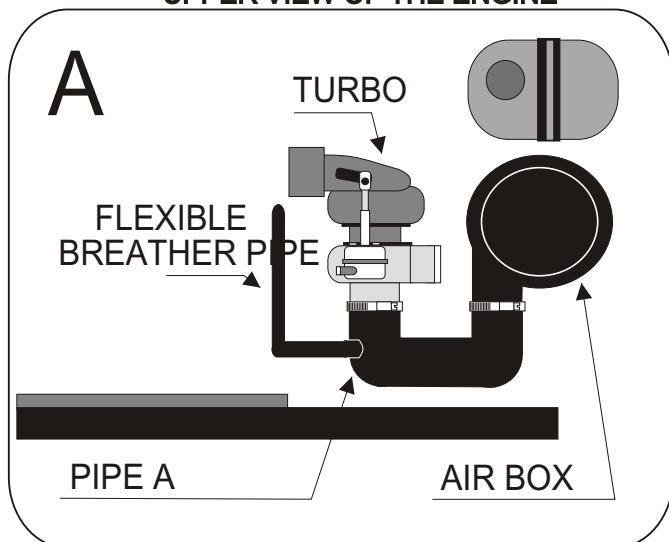

DYNAMIC INDUCTION SYSTEM  
UPPER VIEW OF THE ENGINE

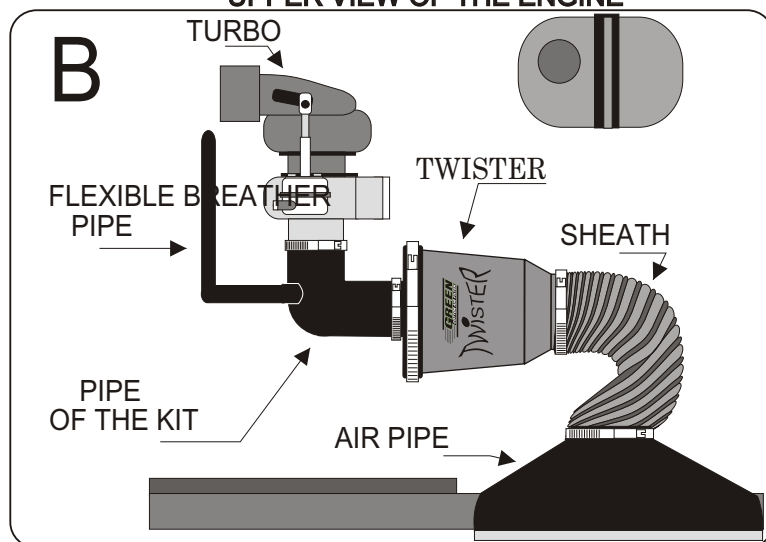

### IMPORTANT:

The running of your engine is linked directly with the maintenance of the air filter. Clean your air filter every 7000 kms or 4500 miles with Green cleaning products.

### WARRANTY:

The air filter guarantee is for defects in materials and workmanship only. Guarantee is void if the air filter is damaged by an accident, unreasonable use, neglect, misuse, abuse, improper installation or other causes not arising out of defects in materials and workmanship. The induction kit is a technical product so it is necessary to have some basic mechanical skills. If problems do not hesitate to have your induction kit fitted by a professional.



## Comment utiliser et entretenir votre filtre à air AIR FILTER SERVICE INSTRUCTIONS

Votre filtre à air doit être nettoyé entre 7000 kms et 10000 kms. ou tous les 6 mois.

La périodicité de nettoyage est directement liée à l'environnement dans lequel vous circulez.

### Procédure de nettoyage des filtres

**UTILISER EXCLUSIVEMENT LES PRODUITS D'ENTRETIEN RECOMMANDÉS PAR GREEN**

- Déposer le filtre.
- Souffler le filtre, afin d'évacuer le plus gros des impuretés.
- ATTENTION- maintenir la "soufflette" à une distance d'environ 15cm.
- Imprégner le filtre de nettoyant GREEN.
- Laisser agir le produit environ 15 minutes.

- Vous pouvez frotter le filtre à l'aide d'un pinceau
- Rincer le filtre à l'eau CHAUDE, par l'intérieur puis par l'extérieur
- Pour les filtres fortement encrassés, n'hésitez pas à renouveler l'opération.
- Secouer le filtre pour évacuer l'eau.
- Il est possible de se servir d'air comprimé pour évacuer l'eau.
- Faites sécher le filtre sur un radiateur tiède, ou à l'aide d'un sèche-cheveux.
- Vaporiser l'huile GREEN sur toute la surface du filtre, uniformément mais sans excès



## How to use and maintain your air filter AIR FILTER SERVICE INSTRUCTIONS

It is essential to oil the GREEN filter using the supplied quantity of oil. Clean your air filter between 7000 km and 10000 km or every 6 months.

Cleaning periodicity is linked directly to the environment in which you drive.

### Procedure for cleaning the GREEN filters

**USE EXCLUSIVELY THE MAINTENANCE PRODUCTS RECOMMENDED BY GREEN**

- Remove the filter
- Blow out the filter to expel the largest impurities
- CAUTION: maintain the blower at a distance of 15 cm or so.
- Impregnate the filter with GREEN cleaner
- Allow the product to act for about 15 minutes
- You can rub the filter with a paint brush
- Rinse the filter with hot water first on the inside then on the outside
- For deeply fouled filters, be sure to repeat the operation
- Shake the filter to evacuate the water
- Compressed air can be used to evacuate the water
- Dry the filter on a tepid radiator or using a hair dryer
- Spray GREEN oil onto the entire surface of the filter, uniformly but not excessively

# NOMENCLATURE

Article	Référence	Q
FILTRE FILTER	TW 70	1
CANALISATION FLEXIBLE PIPE	DUR 0105R	1
MANCHON SLEEVE	M2D60	1
COLLIER CLAMP	130/150	1
COLLIER CLAMP	70/90	4
GAINÉ SHEATH	G80TW1000	1
COLLIER PLASTIQUE PLASTIC CLAMP	CP 360	4
HUILE	H50	1
EMBALLAGE	CAS 217	1



## Como utilizar y cuidar su filtro para aire AIR FILTER SERVICE INSTRUCTIONS

Su filtro para aire debe ser limpiado entre los 7000 km y los 10.000 km o cada seis meses.

La periodicidad de limpieza es directamente ligada con el medio ambiente en el que circula usted.

### Proceso de limpieza de los filtros

**UTILIZAR EXCLUSIVAMENTE LOS PRODUCTOS DE LIMPIEZA RECOMENDADOS POR GREEN**

- Depositar el filtro.
- Soplar el filtro a fin de despejar el máximo de impurezas.
- CUIDADO: mantener el fuelle a una distancia de unos 15 cm.
- Impregnar el filtro con el producto para la limpieza Green.
- Dejar el producto actuar unos 15 minutos.
- Puede usted frotar el filtro con un pincel.
- Enjuagar el filtro con agua caliente, por el interior y luego por el exterior.
- Para los filtros muy ensuciados, no vacile en repetir la operación.
- Sacudir el filtro para quitar el agua.
- Es posible utilizar aire comprimido para quitar el agua.
- Seque usted el filtro en un radiador tibio o utilice un secador.
- Vaporizar el aceite Green en toda la superficie del filtro uniformemente pero sin exeso.

