



## KIT ADMISSION DIRECTE DIRECT INDUCTION KIT

PONY & EXCEL 1.5L 12V  
(fitting with flow meter) 94 <

S.A.S  
**Chrono'Sport**  
122 rue du faubourg Saint Jean  
ZA de l'AVELON - 60000 BEAUVAIS -  
FRANCE  
00.33.3.44.02.64.64  
00.33.3.44.02.87.10

**Part n° :P109**

## FITTING INSTRUCTION

- Remove the pipe which links the throttle box to the air flow meter .
- Remove the air box.
- Disconnect the air flow meter from the air box.
- Disconnect the temperature probe from the air box then fix it to the pipe C of the kit.
- Fix the pipe B of the kit to the throttle box.
- Fix the air flow meter to the pipe B of the kit.
- Fix the pipe C of the kit to the air flow meter.
- Fix the filter to the pipe C with the sleeve provided.
- Swivel the pipe of the kit in order to place the filter correctly.
- Fix the pipe A to the pipe B of the kit with the sleeve.
- Adjust the filter so that it does not touch a mechanical part.

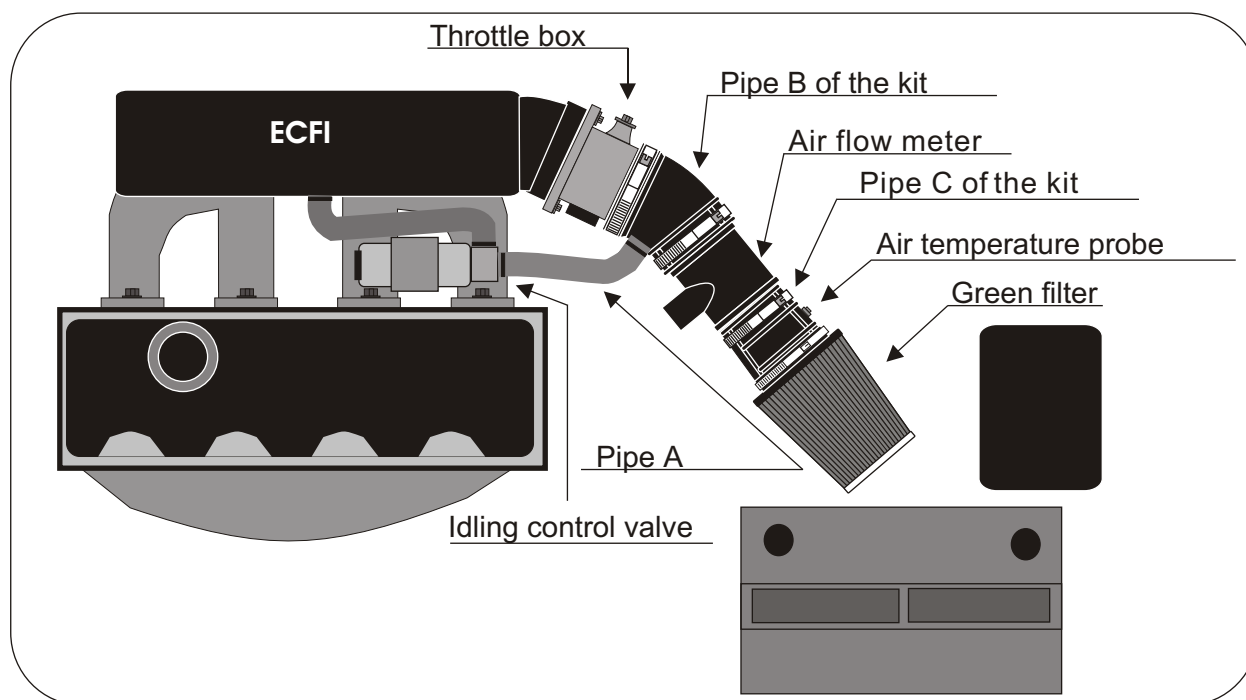

### IMPORTANT:

The running of your engine is linked directly with the maintenance of the air filter. Clean your air filter every 7000 kms or 4500 miles with Green cleaning products..

### WARRANTY:

*The air filter guarantee is for defects in materials and workmanship only. Guarantee is void if the air filter is damaged by an accident, unreasonable use, neglect, misuse, abuse, improper installation or other causes not arising out of defects in materials and workmanship. The induction kit is a technical product so it is necessary to have some basic mechanical skills. If problems do not hesitate to have your induction kit fitted by a professional.*

Green Technical dept : TEL: 00.33.3.44.02.64.64