



S.A.S
Chrono'Sport
122 rue du faubourg Saint Jean
ZA de l'AVELON - 60000 BEAUVAIS -
FRANCE

DIRECT INDUCTION KIT

KIT ADMISSION DIRECTE

SEAT IBIZA 1.4 il
(Mono-point injection)

00.33.3.44.02.64.64
 00.33.3.44.02.87.10

Part n° :P111

FITTING INSTRUCTION

- 1)- Remove the complete air box and the hot air sheath.
- 2)- Remove the negative pressure pipes A and B.
- 3)- Block up the negative pressure pipe A at the 90 ° bend.(see diagram B)
- 4)- Fit the GREEN filter onto the mono-point carburator, then tighten it with the clamp provided in the kit.
- 5)- Fix the small Green filter with its connector to the flexible breather pipe.

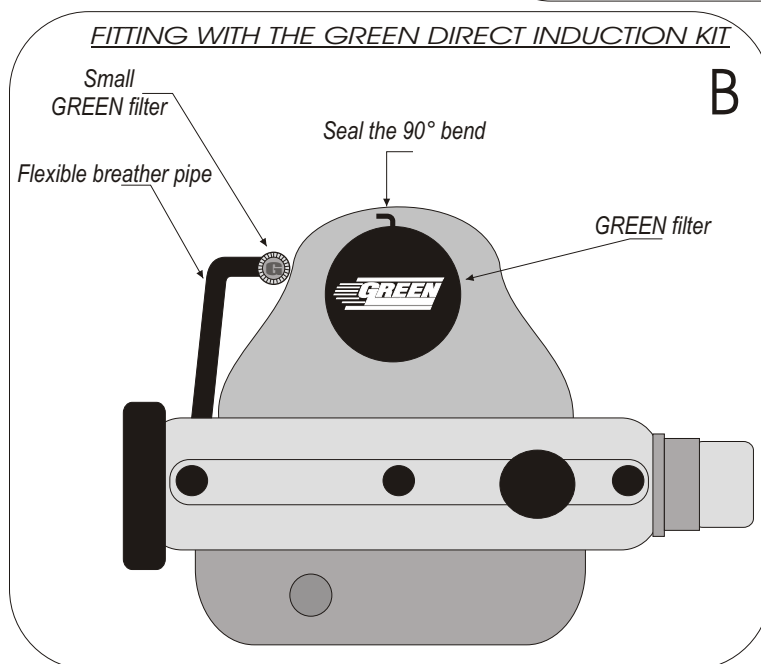
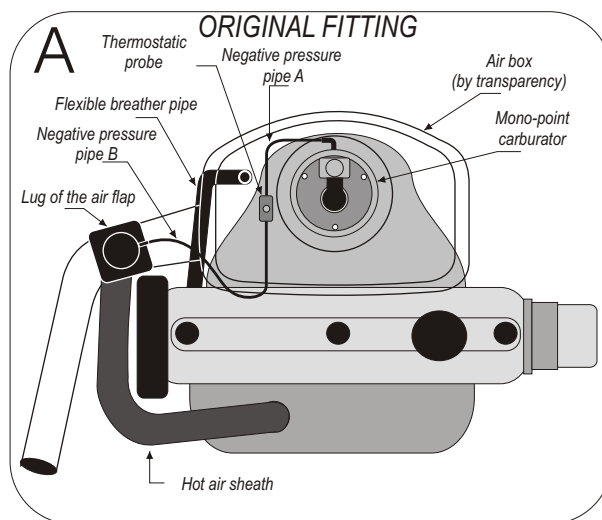

IMPORTANT:

The running of your engine is linked directly with the maintenance of the air filter. Clean your air filter every 7000 kms or 4500 miles with Green cleaning products..

WARRANTY:

The air filter guarantee is for defects in materials and workmanship only. Guarantee is void if the air filter is damaged by an accident, unreasonable use, neglect, misuse, abuse, improper installation or other causes not arising out of defects in materials and workmanship. The induction kit is a technical product so it is necessary to have some basic mechanical skills. If problems do not hesitate to have your induction kit fitted by a professional.

Green Technical dept : TEL: 00.33.3.44.02.64.64