



KIT ADMISSION DIRECTE DIRECT INDUCTION KIT

PEUGEOT 206 1.6L 90HP
Multipoint injection

S.A.S.
Chrono'Sport
122 rue du faubourg Saint Jean
ZA de l'AVELON - 60000 BEAUVAIS -
FRANCE
00.33.3.44.02.64.64
00.33.3.44.02.87.10

Part n° :P177

FITTING INSTRUCTION

Disconnect the idling control valve pipe which is under the flexible pipe of the throttle box.
this pipe will not be reconnected.

Disconnect the oil vapor recycling pipe in the flexible pipe from the throttle box.

To disconnect pipes, pinch the plastic bush on the sleeve.

Remove air box and soundproof box.

Disconnect the flexible pipe on the idling control valve (a) as in diagram A.
This flexible pipe will not be reconnected.

Fix the small GREEN filter to the idling control valve.

Fix the induction kit to the throttle box taking care to remove the sealant.

Fix oil vapor recycling pipe to the sleeve of the kit.

NOTE: this pipe is just positionned in the sleeve of the kit, the watertightness between these two parts is not necessary.

Fix the air fresh pipe to original air box and bend it towards the GREEN filter.

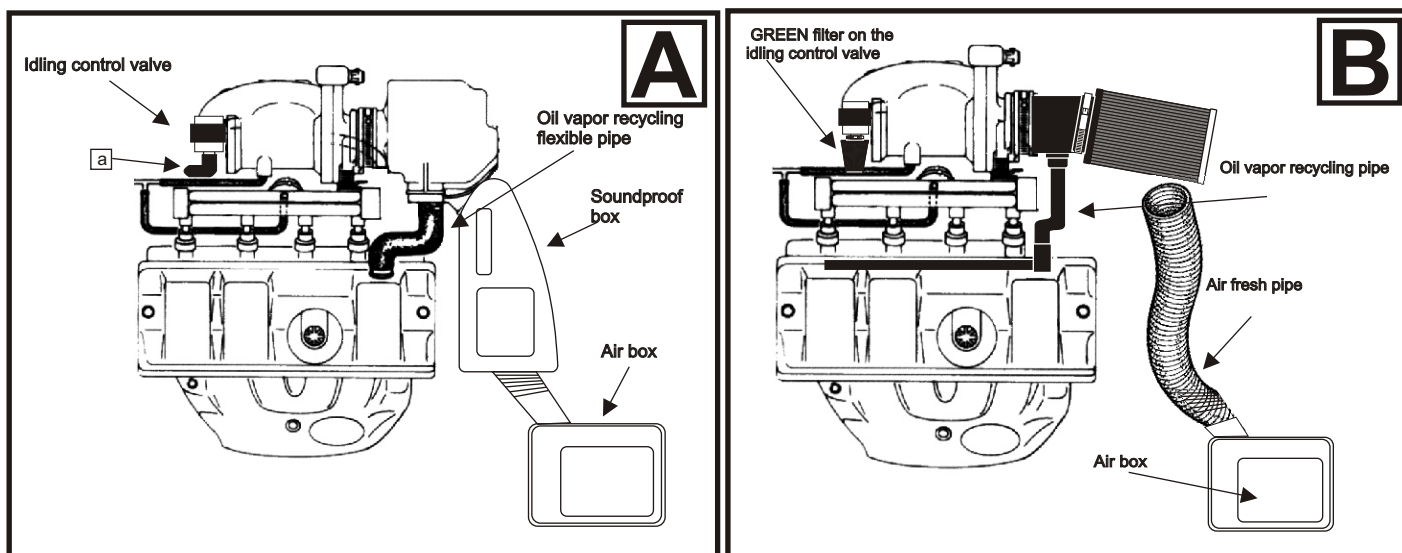

IMPORTANT:

The running of your engine is linked directly with the maintenance of the air filter. Clean your air filter every 7000 kms or 4500 miles with Green cleaning products.

WARRANTY:

The air filter guarantee is for defects in materials and workmanship only. Guarantee is void if the air filter is damaged by an accident, unreasonable use, neglect, misuse, abuse, improper installation or other causes not arising out of defects in materials and workmanship. The induction kit is a technical product so it is necessary to have some basic mechanical skills. If problems do not hesitate to have your induction kit fitted by a professional.

Green Technical dept : TEL: 00.33.3.44.02.64.64