



KIT ADMISSION DIRECTE DIRECT INDUCTION KIT

FIAT UNO 1.0L IE
MONOPOINT INJECTION

S.A.R.L

Chrono'Sport

122 rue du faubourg Saint Jean
ZA de l'AVELON - 60000 BEAUVAIS -
FRANCE

 00.33.3.44.02.64.64

 00.33.3.44.02.87.10

Part n° :P263

FITTING INSTRUCTION

Remove the complete air box.

Remove the attaching bracket of the air box (on the carburator) (3 nuts of 6 mm diameter)

Screw the three large nuts then the three threaded bars at the place of the 6 mm nuts (see diagram C).

Fix the green filter to the carburator then position the three washers and the three nuts.

(See diagram B)

CAUTION THE FOLLOWING IS VERY IMPORTANT,

IT IS ABOUT THE TIGHTNESS AND THE LIFESPAN OF YOUR AIR FILTER

- **Tighten method of the lock nuts:**

a) Tighten the nut until contact with the washer (when you will not be able to turn the washer with your finger).

b) Tighten a quarter turn NOT MORE .

The filter is now tightenned enough to have a tightness onto the carburator and not too much for not deteriorating it.

Another tightennning will be useless

Fix the green filter to the oil vapor pipe.

Fix the negative pressure pipe at the end of the small green filter.

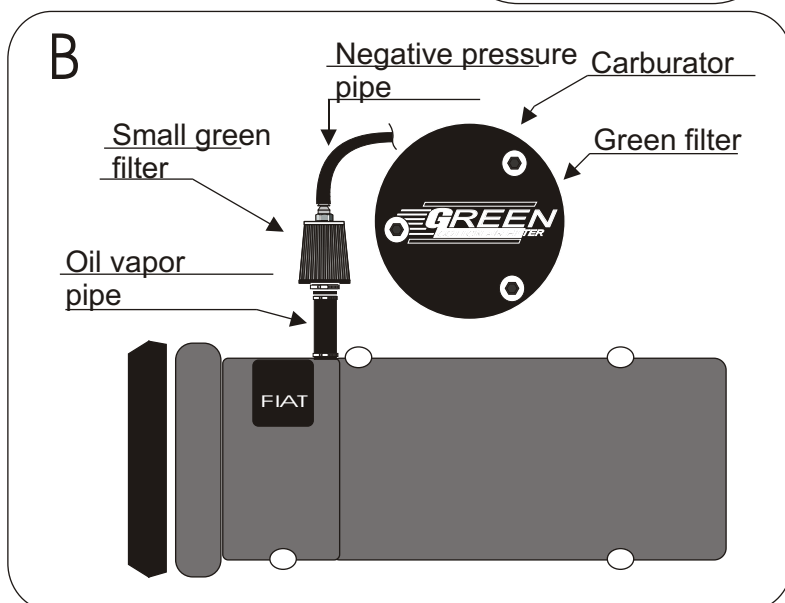
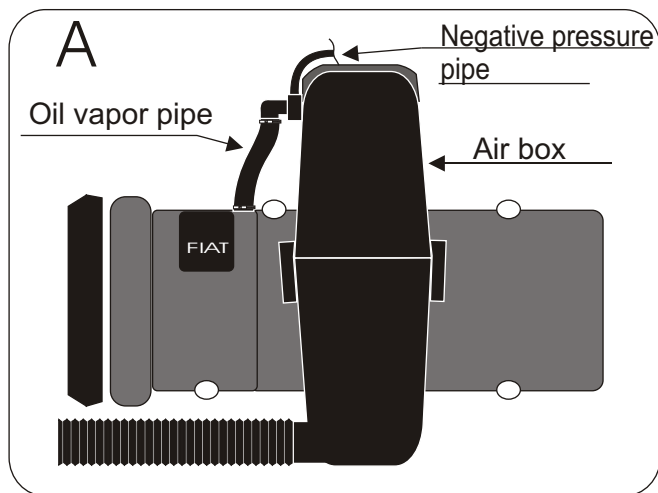
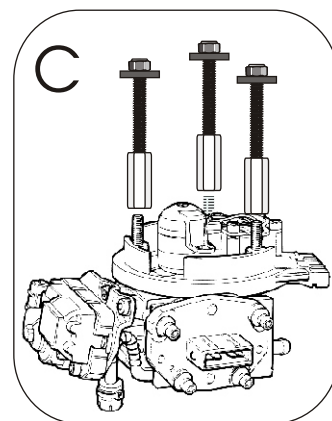

IMPORTANT:

The running of your engine is linked directly with the maintenance of the air filter. Clean your air filter every 7000 kms or 4500 miles with Green cleaning products.

WARRANTY:

The air filter guarantee is for defects in materials and workmanship only. Guarantee is void if the air filter is damaged by an accident, unreasonable use, neglect, misuse, abuse, improper installation or other causes not arising out of defects in materials and workmanship. The induction kit is a technical product so it is necessary to have some basic mechanical skills. If problems do not hesitate to have your induction kit fitted by a professional.

Green Technical dept : TEL: 00.33.3.44.02.64.64