



KIT ADMISSION DIRECTE DIRECT INDUCTION KIT

FORD KA 1.3L INJECTION

S.A.R.L

Chrono'Sport

122 rue du faubourg Saint Jean
ZA de l'AVELON - 60000 BEAUVAIS -
FRANCE

 00.33.3.44.02.64.64

 00.33.3.44.02.87.10

Part n° :P308

FITTING INSTRUCTION

Remove the air box and the pipe A .(see diagram A)

Disconnect the air temperature probe from the air box then fix it to the pipe of the kit.(see diagram B)

Disconnect the air flow meter from the air box .

Fix the pipe of the kit onto the throttle box.(see diagram B)

Fix the air flow meter onto the pipe of the kit and the green filter.(see diagram B)

Fix the oil vapor pipe onto the connector provided.(see diagram B)

Adjust the filter so that it does not touch a mechanical part

CAUTION

To connect the air temperature probe, it is necessary to make longer the original electric harness, for that, use the thread and the thermoretractable sheath provided.

Disconnect the electric harness from the air temperature probe.

Bare the white/ violet thread then make it longer with the black thread provided.

Bare the white/marron thread then make it longer with the black thread provided.

Make a splice on each thread as in diagram C.

Place the thermoretractable sheath to each splice and heat it with a lighter until a minimum thickness.

(see diagram D)

CAUTION

The threads provided in the kit have different colors to avoid a reversal of the original electric harness.

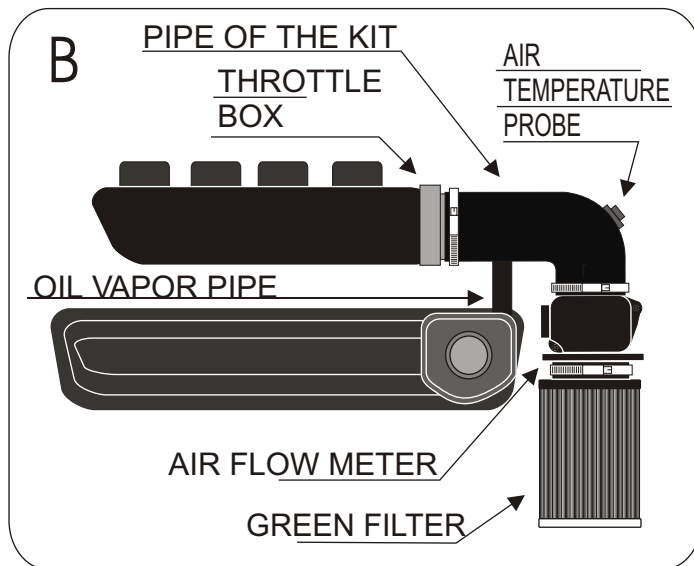
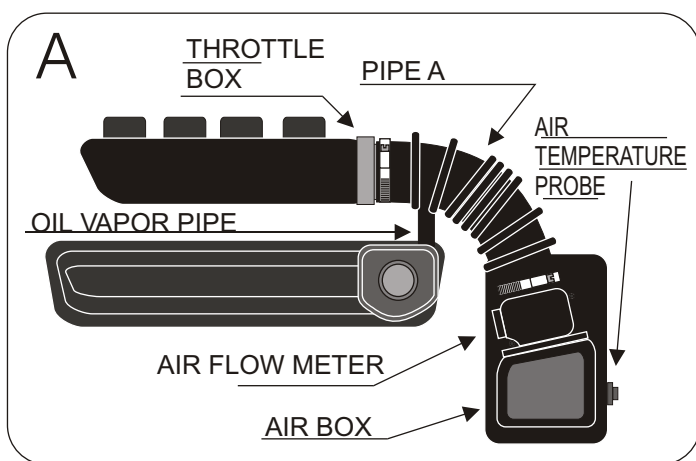
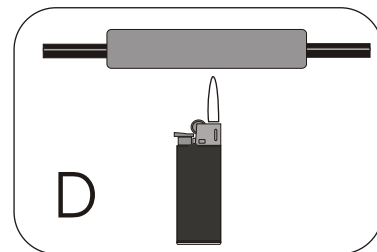
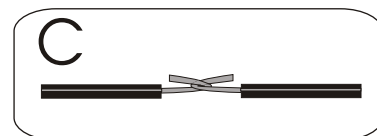

IMPORTANT:

The running of your engine is linked directly with the maintenance of the air filter. Clean your air filter every 7000 kms or 4500 miles with Green cleaning products.

WARRANTY:

The air filter guarantee is for defects in materials and workmanship only. Guarantee is void if the air filter is damaged by an accident, unreasonable use, neglect, misuse, abuse, improper installation or other causes not arising out of defects in materials and workmanship. The induction kit is a technical product so it is necessary to have some basic mechanical skills. If problems do not hesitate to have your induction kit fitted by a professional.

Green Technical dept : TEL: 00.33.3.44.02.64.64