



## KIT ADMISSION DIRECTE DIRECT INDUCTION KIT

BMW Z3 ROADSTER 6CYL.  
2.8L 192 HP

S.A.S  
**Chrono'Sport**  
122 rue du faubourg Saint Jean  
ZA de l'AVELON - 60000 BEAUVAIS -  
FRANCE  
00.33.3.44.02.64.64  
00.33.3.44.02.87.10

**Part n° :P341**

# FITTING INSTRUCTION

Remove the complete air box. (See diagram A)

Disconnect the air flow meter from the air box.

Fix the pipe of the kit onto the air flow meter. (See diagram B)

Fix the green filter onto the pipe of the kit with the sleeve provided. (See diagram B)

Adjust the filter with the bracket then drill a hole of 8.5mm diameter onto the wheel arch.(see diagram B)  
Fix the filter with the screws provided. (See diagram B)

Adjust the filter so that it does not touch  
a mechanical part.

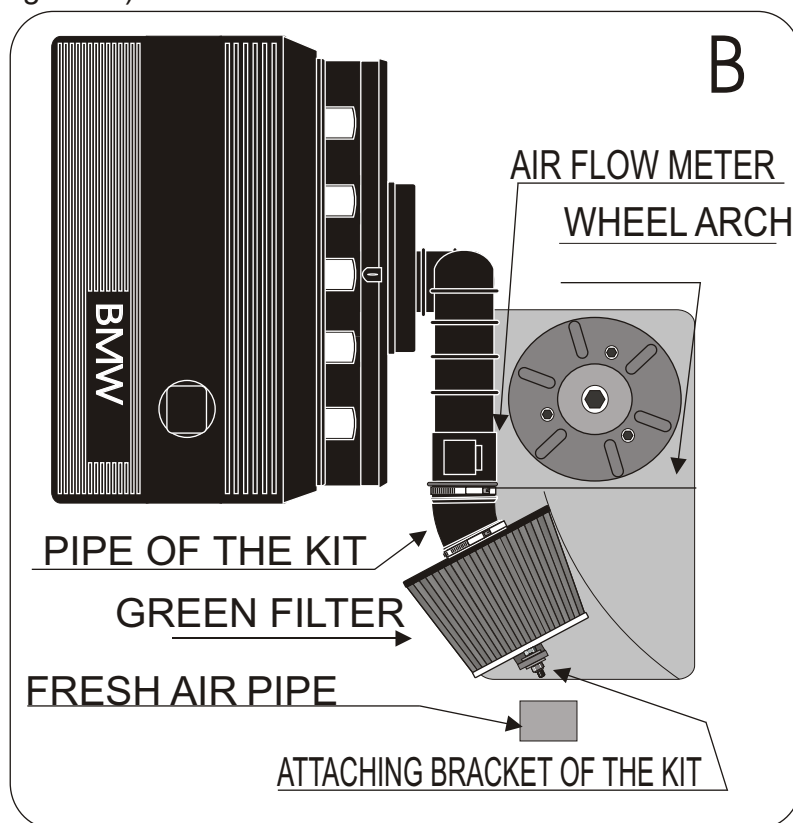
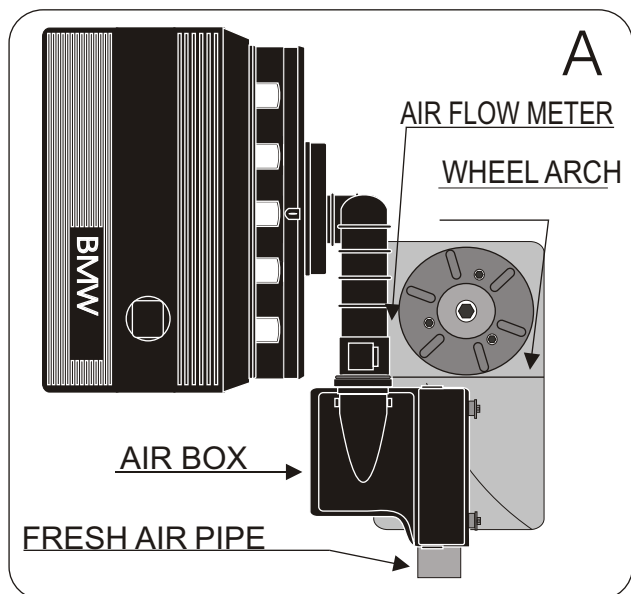

### IMPORTANT:

The running of your engine is linked directly with the maintenance of the air filter. Clean your air filter every 7000 kms or 4500 miles with Green cleaning products.

### WARRANTY:

The air filter guarantee is for defects in materials and workmanship only. Guarantee is void if the air filter is damaged by an accident, unreasonable use, neglect, misuse, abuse, improper installation or other causes not arising out of defects in materials and workmanship. The induction kit is a technical product so it is necessary to have some basic mechanical skills. If problems do not hesitate to have your induction kit fitted by a professional.