



## KIT ADMISSION DIRECTE DIRECT INDUCTION KIT

FIAT BARCHETTA  
1.8L 16V 130HP

S.A.S

**Chrono'Sport**

122 rue du faubourg Saint Jean  
ZA de l'AVELON - 60000 BEAUVAIS -  
FRANCE



00.33.3.44.02.64.64



00.33.3.44.02.87.10

**Part n° :P368**

# FITTING INSTRUCTION

Remove the pipe A, the pipe B and the soundproof box. (See diagram A)

Disconnect the air flow meter from the air box.

Fix the pipe C of the kit onto the pipe A. (See diagram B)

Fix the pipe D of the kit onto the pipe C with the sleeve provided.(see diagram B)

Fix the air flow meter onto the pipe D then fix it with the bracket and the screws provided. (Screw of diameter 8) (diagram B)

**CAUTION** Adjust the pipes C and D. (See diagram B)

Fix the green filter onto the air flow meter.

Fix the oil vapor pipe onto the pipe C with the connector provided.(see diagram B)

Adjust the filter so that it does not touch a mechanical part.

It is not necessary to remove the air box.

Drill the air inlet nozzle of 1 cm so that it does not touch the filter.(see diagram B)

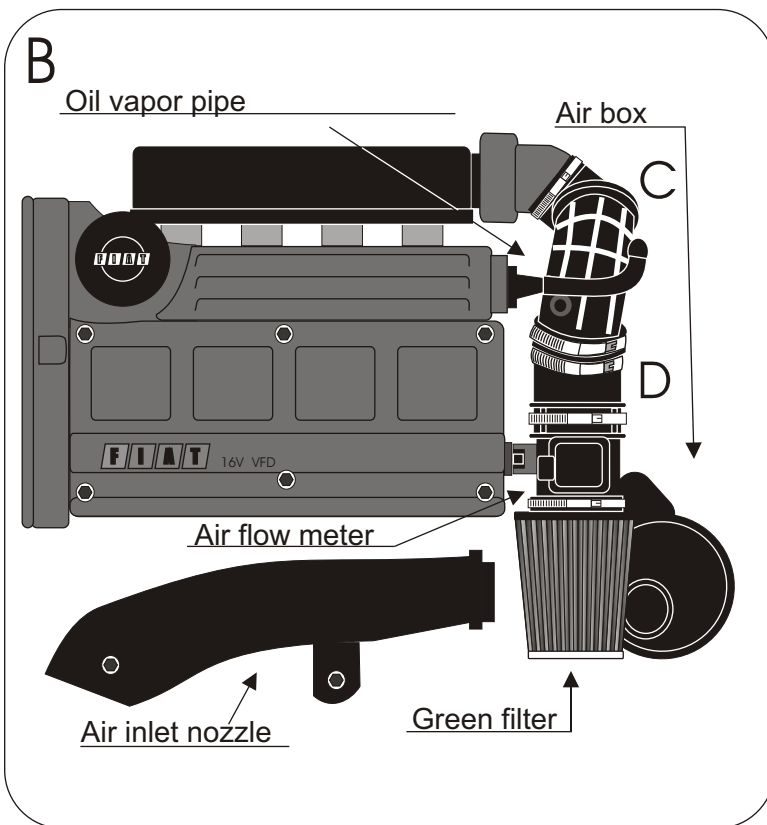
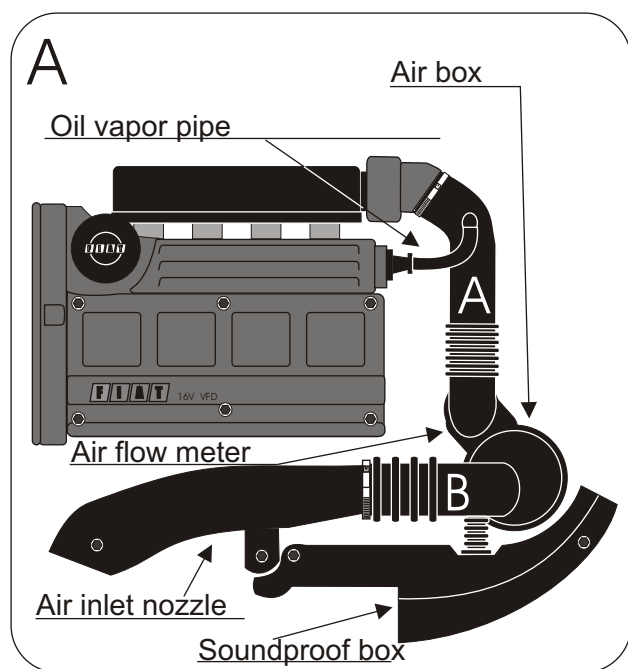

### IMPORTANT:

The running of your engine is linked directly with the maintenance of the air filter. Clean your air filter every 7000 kms or 4500 miles with Green cleaning products.

### WARRANTY:

The air filter guarantee is for defects in materials and workmanship only. Guarantee is void if the air filter is damaged by an accident, unreasonable use, neglect, misuse, abuse, improper installation or other causes not arising out of defects in materials and workmanship. The induction kit is a technical product so it is necessary to have some basic mechanical skills. If problems do not hesitate to have your induction kit fitted by a professional.

Green Technical dept : TEL: 00.33.3.44.02.64.64