



## KIT ADMISSION DIRECTE DIRECT INDUCTION KIT

FIAT MULTIPLAT JTD 105

S.A.S

**Chrono'Sport**

122 rue du faubourg Saint Jean  
ZA de l'AVELON - 60000 BEAUVAIS -  
FRANCE

 00.33.3.44.02.64.64

 00.33.3.44.02.87.10

**Part n° :P374**

# FITTING INSTRUCTION

Remove the complete air box.(see diagram A)

Disconnect the air flow meter from the air box.

Fix the GREEN filter onto the air flow meter with the clamp provided.(see diagram B)

Fix the GREEN filter with the brackets provided under the original air box support.(see diagram C)

Adjust the filter so that it does not touch a mechanical part.

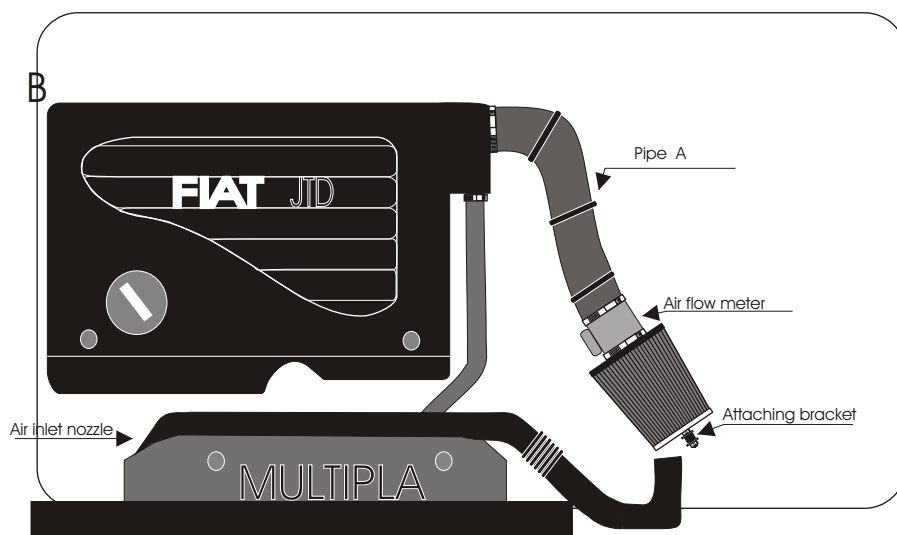
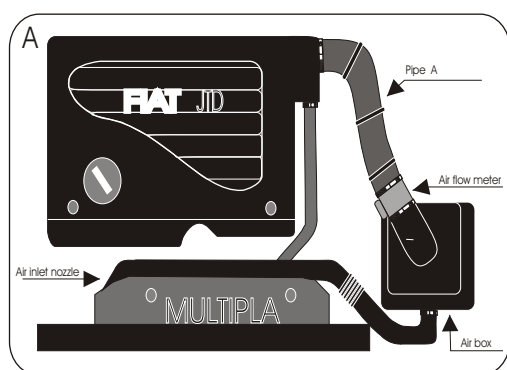
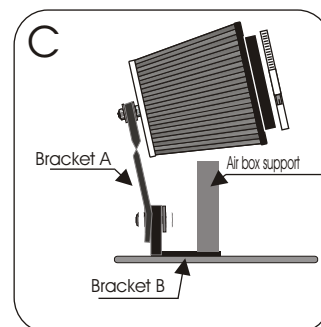

### IMPORTANT:

The running of your engine is linked directly with the maintenance of the air filter. Clean your air filter every 7000 kms or 4500 miles with Green cleaning products.

### WARRANTY:

*The air filter guarantee is for defects in materials and workmanship only. Guarantee is void if the air filter is damaged by an accident, unreasonable use, neglect, misuse, abuse, improper installation or other causes not arising out of defects in materials and workmanship. The induction kit is a technical product so it is necessary to have some basic mechanical skills. If problems do not hesitate to have your induction kit fitted by a professional.*

Green Technical dept : TEL: 00.33.3.44.02.64.64