



KIT ADMISSION DIRECTE DIRECT INDUCTION KIT

HONDA SHUTTLE 2.2L
16V 150 HP

S.A.S
Chrono'Sport
122 rue du faubourg Saint Jean
ZA de l'AVELON - 60000 BEAUVAIS -
FRANCE
00.33.3.44.02.64.64
00.33.3.44.02.87.10

Part n° :P383

FITTING INSTRUCTION

Remove the complete air box.(see diagram A)

Fix the small sleeve onto the pipe A .

Fix the pipe of the kit onto the pipe A with the clamp provided .
(See diagram B)

Fix the GREEN filter with the other sleeve provided in the pipe of the kit.

Adjust the filter with the attaching bracket then drill the cross member with a hole of diameter 08 (See diagram B)

Fix the filter with the attaching bracket and the screws provided.(see diagram B)

Adjust the filter so that it does not touch a mechanical part.

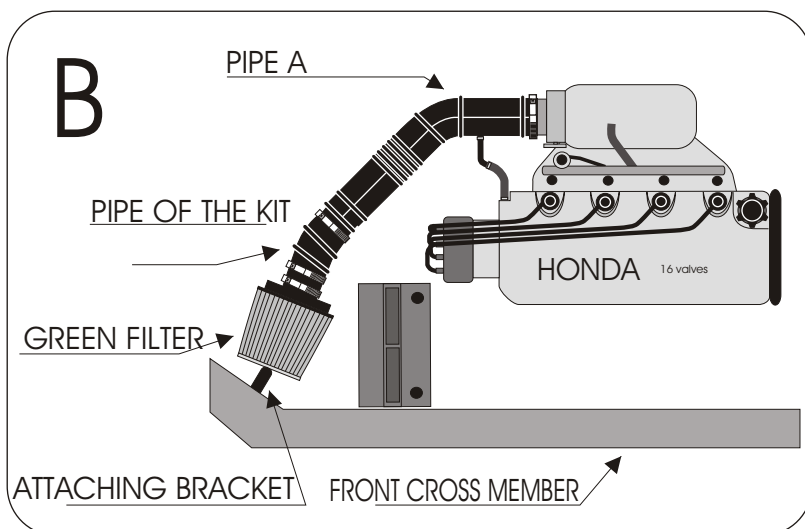
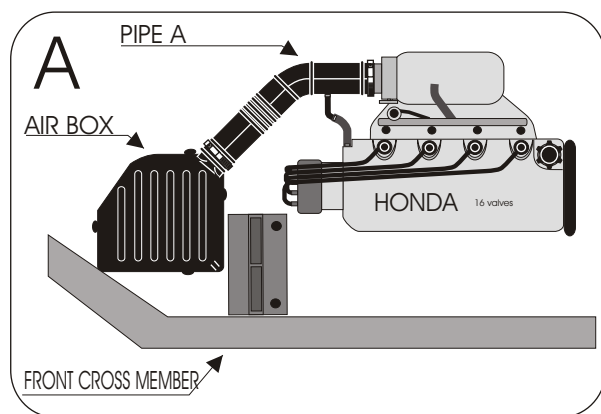

IMPORTANT:

The running of your engine is linked directly with the maintenance of the air filter. Clean your air filter every 7000 kms or 4500 miles with Green cleaning products.

WARRANTY:

The air filter guarantee is for defects in materials and workmanship only. Guarantee is void if the air filter is damaged by an accident, unreasonable use, neglect, misuse, abuse, improper installation or other causes not arising out of defects in materials and workmanship. The induction kit is a technical product so it is necessary to have some basic mechanical skills. If problems do not hesitate to have your induction kit fitted by a professional.